

Please read instructions thoroughly before assembling.

Components included with the Single Axis Foot:

- 1 Ankle Pin
- 2 Pin Hole Plugs
- 2 Ankle Joint Bushings (factory-installed in foot)

Components included with Exoskeletal SA Ankle:

- 1 Exoskeletal SA Ankle (includes pre-installed Ankle Pin Retaining Screw)
- 1 Exoskeletal SA Wood Ankle Block (factory-installed onto Exoskeletal SA Ankle)
- 2 Flat Head Capscrews, Plated, 1/4"-20 x 2" and 1/4"-20 x 2.75"
- 1 Exoskeletal SA Foam Ankle
- 1 Lamination Cap (for laminating only)
- 2 Socket Head Capscrews, 1/4"-20 x 2.5", with Seal Plugs (for laminating only)

Components to be ordered separately:

- 1 Anterior Deflection Bumper: soft (blue), medium (black), or firm (white)
- 1 Posterior Deflection Bumper: soft (yellow), medium (green), or firm (red)

Additional materials needed: Foot Pyramid (Part No. 2LTC-1208 or equivalent) or Berkeley foot plate, foot bolt, two-part foam, carbon tape, Rubatex Adhesive or equivalent, Loctite 242 or equivalent, standard lab supplies (stockinette, resin, etc.)

Section 1 — Exoskeletal SA Wood Ankle Block Shaping

1. Place the 1.5" (38mm) long Posterior Deflection Bumper onto the rivet at the rear of the foot.
2. Place the 1" (25mm) long Anterior Deflection Bumper onto the rivet at the front of the foot.
3. Place the Exoskeletal SA Ankle, with the Exoskeletal SA Wood Ankle Block attached to it, on top of the foot and Deflection Bumpers so that the thicker end of the ankle is located anteriorly. Push the Exoskeletal SA Ankle down so that the hole in the Exoskeletal SA Ankle lines up with the holes in the sides of the foot (Figure 1).

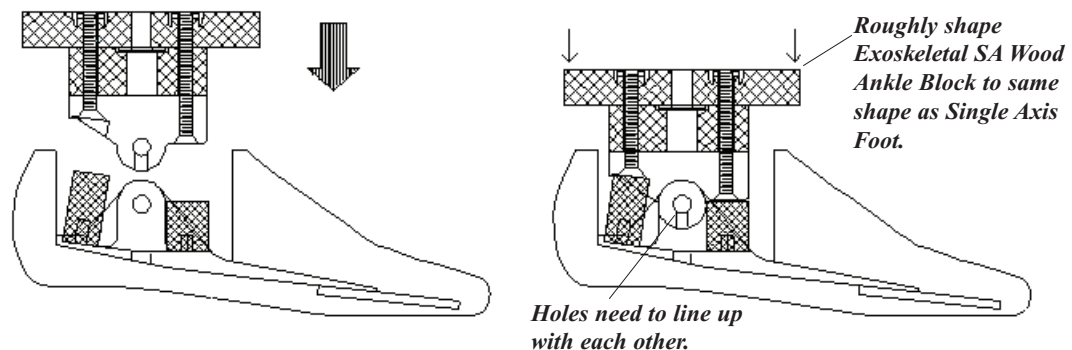

Figure 1 Assembly of Exoskeletal SA Wood Ankle Block and Exoskeletal SA Ankle to Single Axis Foot



OHIO WILLOW WOOD®
free the body...free the spirit®
15441 Scioto Darby Road
Mt. Sterling, OH 43143
phone 740.869.3377 / 800.848.4930
fax 740.869.4374 www.owwco.com



EC REP

Ohio Willow Wood Company B.V.
Keizersgracht 62/64
1015 CS Amsterdam
The Netherlands



PN-1127-D 9 JUL 2009

4. Insert a 4mm Allen wrench into the hex head on the end of the ankle pin.
5. Insert the Ankle Pin into the foot through either one of the holes in the sides of the foot. Push the Ankle Pin firmly or lightly tap the end of the Ankle Pin with a hammer to ensure that the pin is properly seated inside the foot.
6. Place the foot and Exoskeletal SA Wood Ankle Block assembly upside down on a table and trace the shape of the foot at the ankle onto the underside of the Exoskeletal SA Wood Ankle Block.

Caution: Do not mark the foot cosmesis when marking the Exoskeletal SA Wood Ankle Block.

7. Push the Ankle Pin out from the side of the foot.
8. Separate the Exoskeletal SA Ankle from the Single Axis Foot, then separate the Exoskeletal SA Wood Ankle Block from the Exoskeletal SA Ankle.
9. Cut the Exoskeletal SA Wood Ankle Block to roughly the shape of the foot that was marked in step 6. Sand the edges of the Exoskeletal SA Wood Ankle Block.

Section 2 — Alignment

1. Attach a suitable foot pyramid (Part No. 2LTC-1208 or equivalent) or a Berkeley foot plate to the top of the Exoskeletal SA Wood Ankle Block with an appropriate foot bolt. Be sure to install the foot pyramid or Berkeley foot plate on the side of the Exoskeletal SA Wood Ankle Block that has the large flanges on the T-nuts (refer to Figure 2). Do not use a washer with the bolt, as a flat washer is already installed in the Exoskeletal SA Wood Ankle Block.
2. Tighten the foot bolt to 30 ft-lbs (41 Nm).

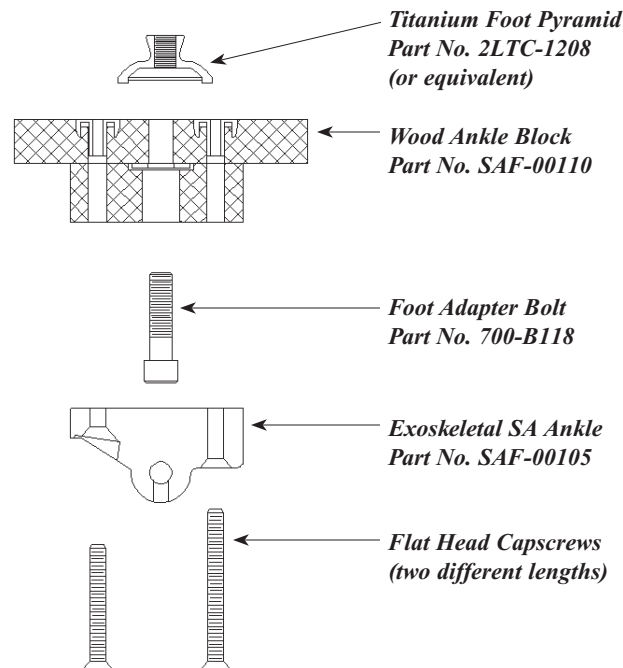

Figure 2 Assembly of Alignment Components (not for definitive use)

-
3. Attach the Exoskeletal SA Ankle to the opposite side of the wood block using the Flat Head Capscrews as shown in Figure 2. Use the longer capscrew at the thicker end of the Exoskeletal SA Ankle (anterior position).
 4. Tighten the Flat Head Capscrews evenly to 10 ft-lbs (14 Nm).
 5. Place the Exoskeletal SA Ankle on top of the foot and Deflection Bumpers so that the thicker end of the ankle is located anteriorly. Push the Exoskeletal SA Ankle down so that the hole in the Exoskeletal SA Ankle lines up with the holes in the sides of the foot.
 6. Insert a 4mm Allen wrench into the hex head on the end of the ankle pin.
 7. Holding the Allen wrench so that the flat surface on the Ankle Pin is facing down, insert the Ankle Pin into the foot through either one of the holes in the sides of the foot. Rotate pin with wrench until end of pin appears as shown in Figure 3.
 8. Insert a 4mm Allen wrench through the hole in the bottom of the foot into the

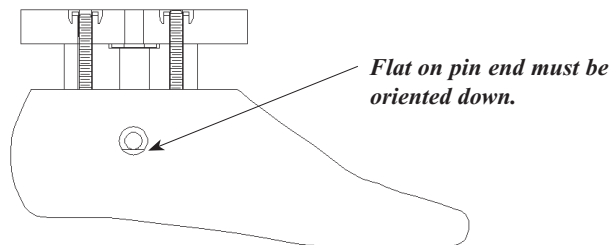

Figure 3 Lamination Assembly

hex head of the Ankle Pin Retaining Screw.

9. Tighten the Ankle Pin Retaining Screw against the flat surface of the Ankle Pin. Torque to 5 ft-lbs (7 Nm).

Caution: Tightening the Ankle Pin Retaining Screw higher than 5 ft-lbs (7 Nm) may damage the screw.

10. Check the pin tightness by inserting the 4mm Allen wrench into the hex head of the Ankle Pin and wiggle the wrench. If the Ankle Pin moves, then the Ankle Pin Retaining Screw has not been firmly tightened against the flat surface of the Ankle Pin, and must be re-tightened.

Warning: Use of the alignment components described above in a definitive prosthesis could result in failure of the components and/or injury to the amputee.

11. Align the prosthesis using standard procedures, changing the anterior and posterior Deflection Bumpers if necessary.

Section 3 — Transfer

1. Loosen (but do not remove) the Ankle Pin Retaining Screw from the hole in the bottom of the Single Axis Foot.
2. Push the Ankle Pin out from one side of the foot.

3. Separate the Exoskeletal Ankle and Exoskeletal SA Wood Ankle Block from the foot by pulling the foot down and off of the ankle.

Note: Leave the Exoskeletal SA Ankle, Exoskeletal SA Wood Ankle Block, foot pyramid, pylon, and socket connected together.

4. Install the temporary prosthesis (without the foot) in a vertical transfer fixture. Restrain the foot assembly by tightening all four pointed screws on the vertical fixture against the sides of the Exoskeletal SA Wood Ankle Block. Restrain the socket using traditional means. Remove all alignment components between the ankle and the socket.
5. Using common fabrication techniques, fill in the area from the Exoskeletal SA Wood Ankle Block to the socket with two-part foam.
6. Remove the cured assembly from the vertical transfer fixture.

Section 4 — Lamination

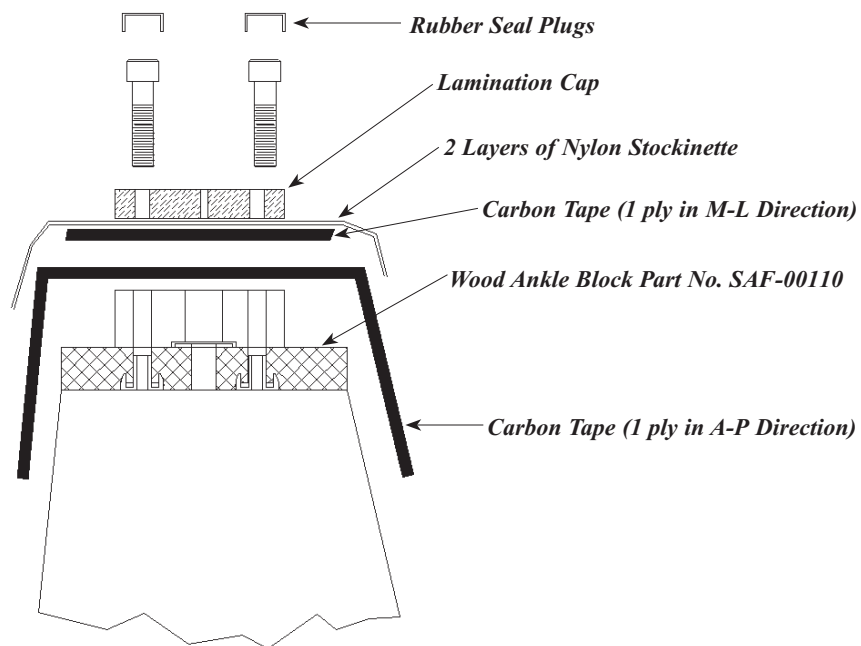

Figure 4 Lamination Assembly

1. Loosen and remove the two Flat Head Capscrews from the underside of the Exoskeletal SA Ankle.
2. Remove the Exoskeletal SA Ankle from the Exoskeletal SA Wood Ankle Block.
3. Shape prosthesis to desired measurements.
4. Install the prosthesis in a laminating fixture. The underside of the Exoskeletal SA Wood Ankle Block should be at the top of this assembly.
5. Cut two pieces of 3" (76 mm) wide continuous carbon tape at least 12" (30 cm) long.

-
6. Place one piece of the carbon tape over the Exoskeletal SA Wood Ankle Block in the A-P direction.
 7. Place the second piece of carbon tape over the Exoskeletal SA Wood Ankle Block in the M-L direction.

Caution: The carbon tapes must be centered over the Exoskeletal SA Wood Ankle Block to provide a strong attachment to the prosthesis.

8. Cut a length of stockinette long enough to cover the prosthesis twice, and apply as follows:
 - a. Sew a seam across the stockinette at the middle of its length.
 - b. Pull one end of the stockinette down until the seam reaches the Exoskeletal SA Wood Ankle Block.
 - c. Orient the seam to either side of the ankle block.
 - d. Pull the rest of the stockinette down over the prosthesis.

Caution: If the seam is not oriented to one side of the Exoskeletal SA Wood Ankle Block, the Lamination Cap will not rest evenly on the layup.

9. Pierce the lamination layup at the two locations for the T-nuts.
10. Place the Lamination Cap on top of the layup, aligning the two holes in the Lamination Cap with the holes in the Exoskeletal SA Wood Ankle Block.
11. Coat the two Socket Head Capscrews with wax or petroleum jelly.
12. Use the two Socket Head Capscrews to tighten the Lamination Cap against the Exoskeletal SA Wood Ankle Block, sandwiching the layup in the middle.
13. Firmly push the two grey Seal Plugs over the two Socket Head Capscrews.

Note: The distal end of the prosthesis should be flat in the area where the Exoskeletal SA Ankle attaches to it.

14. Cover the prosthesis with a PVA bag and proceed with the lamination.
15. Wrap the outside of the PVA bag around the Lamination Cap with electrical tape during the laminating process before the laminate has cured. This will force unwanted resin from this area.
16. After curing the laminate, remove the PVA bag and the Lamination Cap by removing the two grey Seal Plugs and loosening and removing the two Socket Head Capscrews.

Section 5 — Finishing

1. Attach the Exoskeletal SA Ankle to the laminated exoskeletal prosthesis using the two Flat Head Capscrews supplied. The longer cap screw is used with the thicker end of the Exoskeletal SA Ankle in the anterior position.
2. Tighten the Flat Head Capscrews evenly to 10 ft-lbs (14 Nm).
3. Bevel the edges of the Exoskeletal SA Foam Ankle.
4. Using Rubatex or a similar contact cement, glue the Exoskeletal SA Foam Ankle to the distal end of the laminated prosthesis.

-
5. Attach the foot (with bumpers used during alignment) to the Exoskeletal SA Ankle as done in steps 5 through 11 in Section 2. If desired, glue the distal surface of the Exoskeletal SA Foam Ankle to the top of the foot using Rubatex or a similar contact cement.

Note: Reduce the thickness of the Exoskeletal SA Foam Ankle if necessary.

6. Shape the Exoskeletal SA Foam Ankle to the desired measurements.
7. Insert the two Pin Hole Plugs into the holes on the sides of the cosmesis and secure them with Rubatex or a similar contact cement.
8. Sand the Pin Hole Plugs until they are flush with the foot cosmesis.

Note: If the two Ankle Joint Bushings in the keel need to be replaced, use the Ankle Pin to press them out of the keel. Replace them with new Ankle Joint Bushings (Part No. SAF-00120).