

Replacing Rail Pin Assembly and Detent Cap (Part No. GEO-031)

If adjustments to the Friction Control no longer result in any changes in the amount of friction:

1. With a small regular tip screwdriver, remove the Cover Screws and the Black Caps from both sides of the knee.

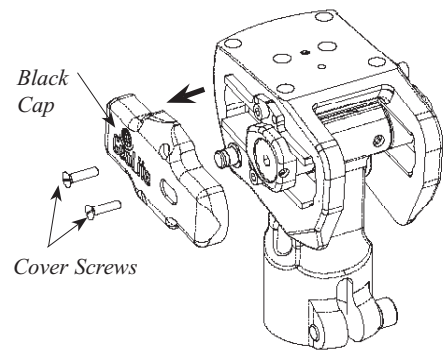

2. With a 5mm hex wrench, slowly and carefully remove the old Detent Cap and Rail Pin Assembly from the Rail Bearing Assembly.

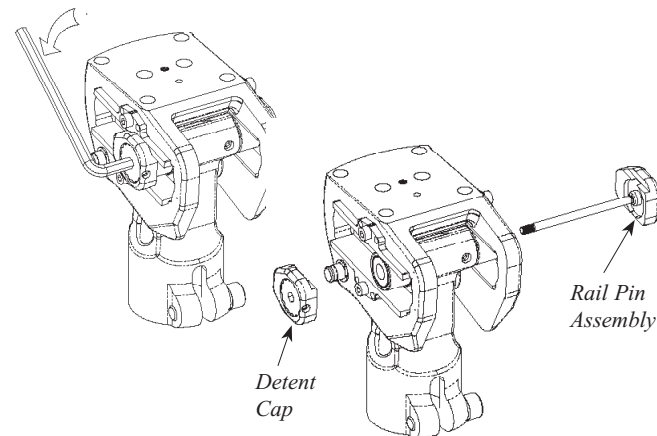

3. Assemble the new Rail Pin Assembly and Detent Cap through the Rail Bearing Assembly.
4. Replace the Black Caps and tighten the Cover Screws.

Dust Cover

The dust cover is recommended for preventing dirt and debris from entering the unit, especially when no foam cover is used.

1. After all adjustments to the knee have been made, remove the foot and slide the Dust Cover over the pylon and onto the knee with the drawstring toward the posterior and proximal end of the knee. The seam on the cover should be facing the posterior side.
2. Flex the knee fully and pull down the distal end of the cover to remove the slack.
3. Gather the slack at the distal end and secure in place with the velcro strap.

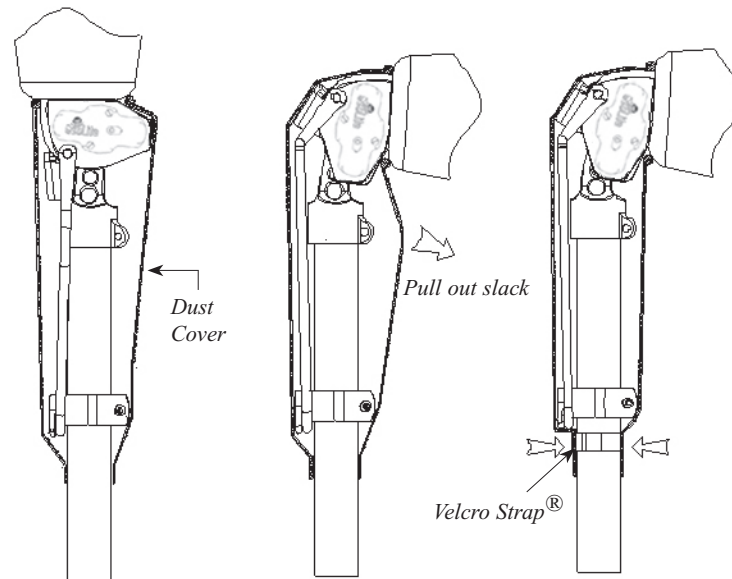

Cosmetic Finishing

A standard foam cover such as the OWW AK Foam Cover (Part No. 700-1AKX-XX), or the Easy Shape AK Foam Cover (Part No. 700-3AKX-XX) may be used to provide a cosmetic cover for the prosthesis.

Maintenance

Some portions of the knee are field-serviceable. Please contact Ohio Willow Wood for repair kits and instructions.

Phone: 740-869-3377 / 800-848-4930

Fax: 740-869-4374

e-mail: info@owwco.com

GeoLite/GeoFlex Troubleshooting

Problem	Solution
The knee feels like it is “catching,” “lagging,” or “bumping” when bending the knee, or the amputee feels a change in the forward movement “like something is hanging up.”	The knee is probably dirty. Blow out the dirt with air pressure. Prosthetists are encouraged to always use the black Dust Cover to prevent further problems. Also, check the lubrication of the Crank Pin and Pivot Pin Bearings. Note: If salt water comes in contact with the knee, it will deteriorate the metal. Be sure the unit is washed, cleaned, and lubricated thoroughly or the warranty will be void.
Amputee hears an unusual clicking noise.	Rail bearings or friction pads in Rail Pin Assembly and Detent Cap are worn down. Replacement parts can be obtained by ordering Rail Bearing Kit GEO-030 or Rail Pin Assembly and Detent Cap Kit GEO-031.
Patient wants less return from the Elastic Extension Assist, but when it is loosened, the assist does not stay on the Tube Clamp.	Secure the Elastic Extension Assist to the Tube Clamp with vinyl adhesive tape.
Amputee with a hip flexion contracture having problems initiating knee flexion.	This is due to the flexion of the socket. To help initiate knee flexion, slide the socket posteriorly.

Alignment and Assembly Instructions for the GeoLite Knee and GeoFlex Knee

IMPORTANT —

Please review the alignment recommendations on pages 3 and 4 to maximize the functional life of the GeoLite and GeoFlex Knees.

Please read instructions thoroughly before assembling a prosthesis using the GeoLite or GeoFlex Knee.

Warranty

Ohio Willow Wood warrants each GeoLite Knee and GeoFlex Knee from the date of purchase for a period of one year against defects in material and workmanship (allowing three weeks for installation). Alternatively, the warranty can begin at the date of fitting ONLY if the warranty card included with the knee is filled out completely and returned to Ohio Willow Wood with a postmark that is within 10 days of the fitting date. A product returned during the warranty period will be evaluated and repaired or replaced at Ohio Willow Wood’s discretion. Use of the GeoLite Knee or GeoFlex Knee for amputees whose adjusted body weight is more than 250 lbs. (115 kg) or who engage in extremely high and abusive activity is against Ohio Willow Wood’s recommendation and will void the one-year warranty. Adjusted body weight is defined as the weight of the amputee plus any loads carried by the amputee. “Extremely high and abusive activities” are defined as activities such as skydiving, karate, and judo; activities that could result in injury to an individual’s natural knee; and activities that expose the prosthesis to corrosives such as salt water.

Warranty Disclaimer

Ohio Willow Wood warrants that each product manufactured will, at the time of delivery, be of workmanlike quality and substantially free of defects. **OHIO WILLOW WOOD MAKES NO OTHER WARRANTY, IMPLIED, OR EXPRESSED, AND MAKES NO WARRANTY OF MERCHANTABILITY OR FITNESS FOR A PARTICULAR PURPOSE.** This warranty shall terminate immediately upon an action to combine our products with other materials or in any manner to change the nature of our products. The sole remedy is replacement of the products or credit for the products. Ohio Willow Wood’s liability shall not exceed the purchase price of the product. **Ohio Willow Wood shall not be liable for any indirect, incidental, or consequential damage.**

Ohio Willow Wood Retention of Rights

Ohio Willow Wood retains all intellectual property rights reflected or incorporated in its physical products, regardless of the transfer of the physical products to another party or parties.



OHIO WILLOW WOOD®
free the body...free the spirit®
15441 Scioto Darby Road
Mt. Sterling, OH 43143
phone 740.869.3377 / 800.848.4930
fax 740.869.4374 www.owwco.com

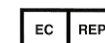

Ohio Willow Wood Company B.V.
Keizersgracht 62/64
1015 CS Amsterdam
The Netherlands



Assembly

Before connecting a component to the proximal 4-hole attachment, check to make sure that the length of exposed screw to engage with the knee is between .16" (4mm) and .25" (6.4mm). Apply Loctite 242 Removable Threadlocker (or equivalent) to the four screws and tighten each one to 12Nm (9 ft-lbs). Be sure to engage the full thread depth of the attachment screws. Make sure that the attachment screws do not bottom out.

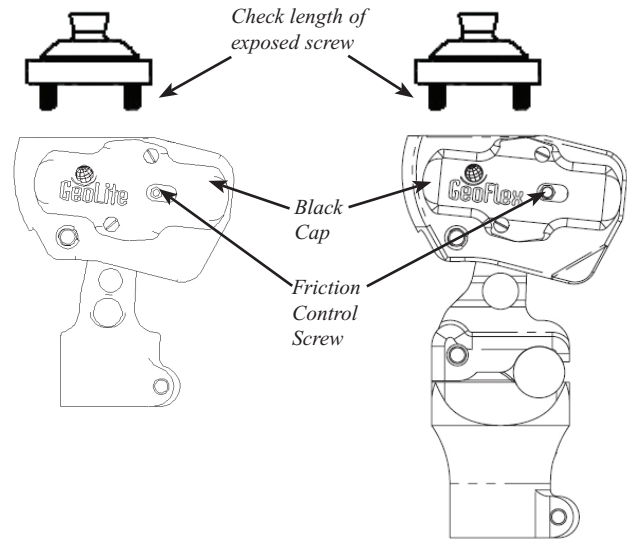

Tighten the bolt on the distal tube clamp to 11-14Nm (8-10 ft-lbs). For subsequent tightening, you may need to increase the torque to 14-16Nm (10-12 ft-lbs).

Note: If for any reason you remove the Black Cap on either side of the knee, be sure to re-install it so that the GeoLite/GeoFlex logo or Ohio Willow Wood logo is right side up, and the friction control screw is visible in the slot. Otherwise you will be unable to access the Friction Control Screw, and the knee will seize.

Alignment — IMPORTANT

The GeoLite/GeoFlex is a polycentric knee with a moving knee center. The reference knee center shown in the diagram below is a reference point for alignment purposes only.

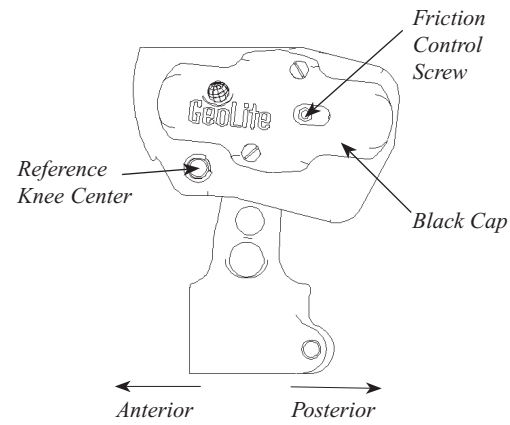

The suggested initial alignment is to position the reference knee center 3/8" (1cm) in front of the Trochanter line. This is the most forward the socket should be at this time.

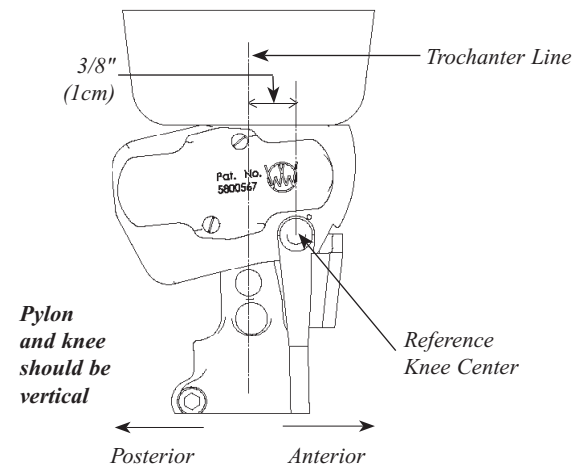

- With a 5mm hex wrench, slowly and carefully remove the Detent Cap and Rail Pin Assembly from the Rail Bearing Assembly.

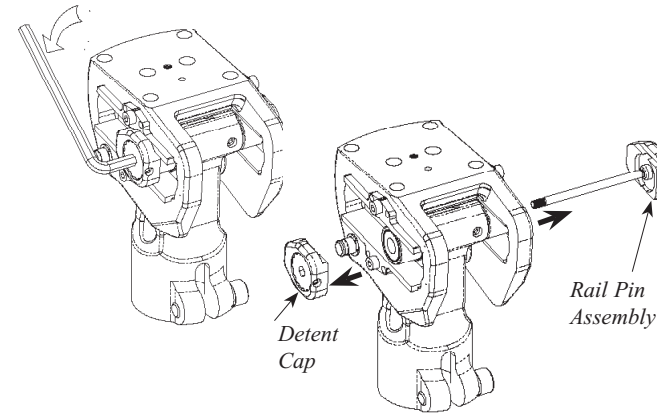

- With a 2.5mm hex wrench, remove the two Lock Setscrews from the rear of the knee.

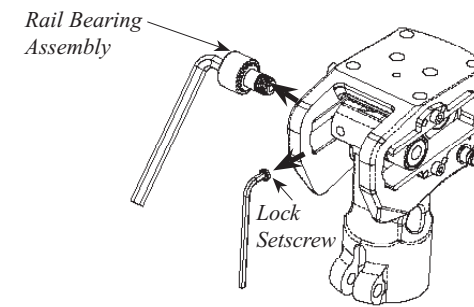

- With a 5mm hex wrench, remove the two Rail Bearing Assemblies.

5. Rail Bearing Lubrication:

- Slide the Outside Race Roller Pin down the Rail Pin Shaft about 10mm. Be careful not to drop the Rail Bearing Assembly, as it is very difficult to reassemble.
- Place the tip of the pre-loaded Lubrication Syringe that was included with the knee (part no. 700-LU001) onto the Rail Bearing Shaft, and inject the lubricant onto the shaft surface.

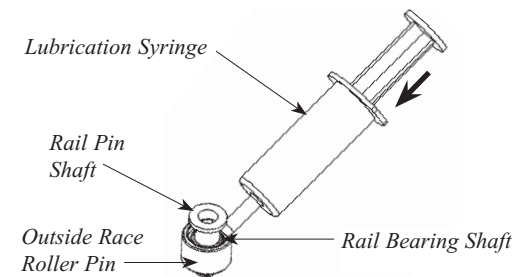

- Slide the Outside Race Roller Pin back into place on the Rail Bearing Shaft.
- Place two drops of Loctite Removable Threadlocker 242 (or equivalent) onto the threads of the Rail Bearing Assembly. Insert the Rail Bearing through the knee top, and tighten on both sides.

- Place a drop of Loctite Removable Threadlocker 242 (or equivalent) onto the Lock Setscrews, and tighten the screws.

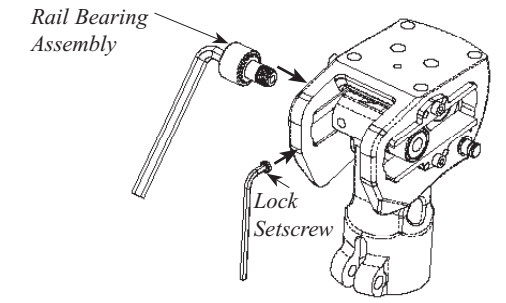

- Assemble the Rail Pin Assembly and Detent Cap through the Rail Bearing Assembly. Tighten the Detent until the desired friction is achieved.

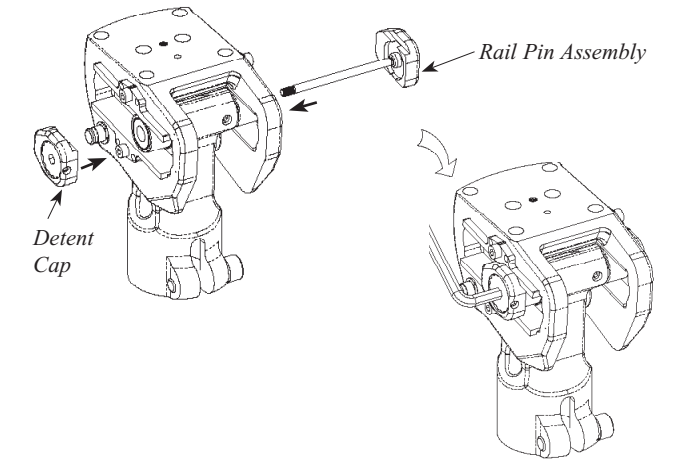

- Re-assemble the Black Caps and tighten the Cover Screws.

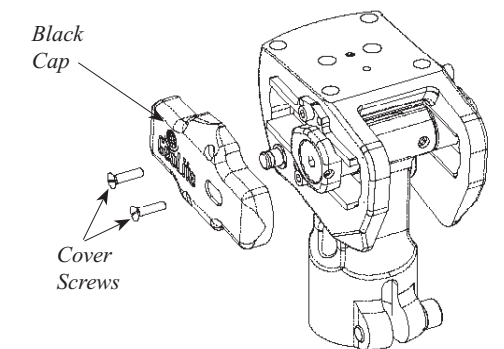

Lubricating the Crank Pin Bearing Assembly

Frequency: every six months, or if the knee is not moving smoothly, or if the knee is exposed to water:

- Using a small regular tip screwdriver, remove the Cover Screws and the Black Cap from the side of the knee that has the patent number on it.

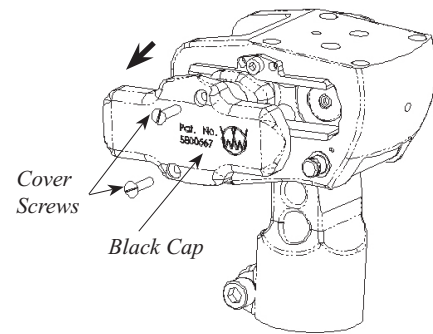

- Using a 2.5mm hex wrench, remove the M5 Setscrew from the Lubrication Port in the Crank Pin.

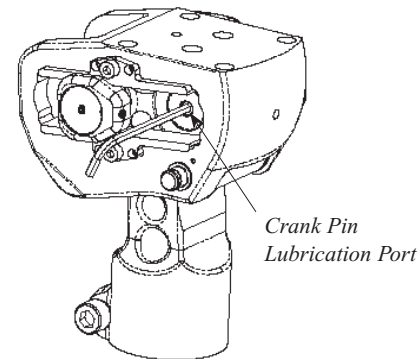

- Place the tip of the pre-loaded Lubrication Syringe that was included with the knee (part no. 700-LU001) into the Lubrication Port. Push the plunger of the Syringe in about 20mm. Try not to overfill the bearing chamber.

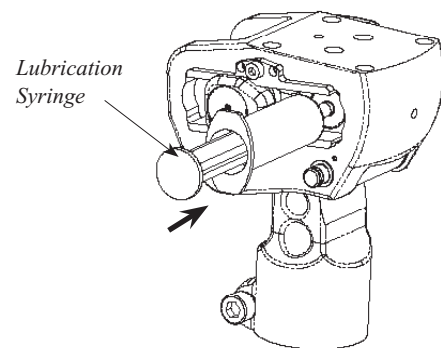

- Re-install the M5 Setscrew and tighten the screw.
- Re-install the Black Cap.

Lubricating the Pivot Pin Bearing Assembly

Frequency: every six months, or if the knee is not moving smoothly, or if the knee is exposed to water:

- Using a 2.5mm hex wrench, remove the M5 Setscrew from the Lubrication Port on the Crank Assembly.

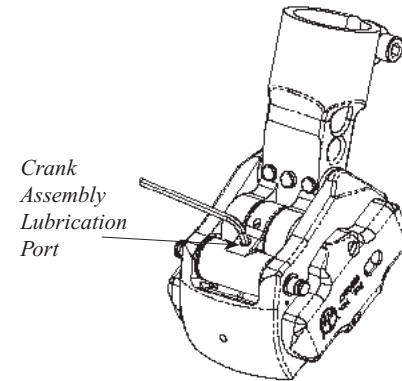

- Place the tip of the pre-loaded Lubrication Syringe that was included with the knee (part no. 700-LU001) into the Lubrication Port. Push the plunger of the Syringe in about 20mm. Try not to overfill the bearing chamber.

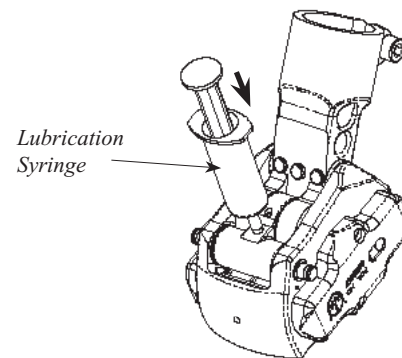

- Replace the M5 Setscrew and tighten the screw.

Replacing or Lubricating the Rail Bearing Assembly (Part No. GEO-030)

If the knee is making a clicking noise or exhibiting medial/lateral play:

- With a small regular tip screwdriver, remove the Cover Screws and the Black Caps from **both** sides of the knee.

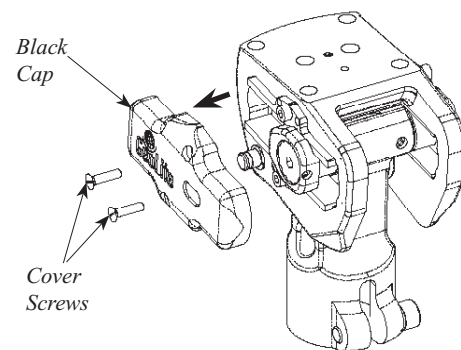

KEY FOR STABILITY:

From this initial position, the socket can be shifted up to 1" (2.5cm) in the posterior direction to encourage the initiation of knee flexion without losing stability. **Shifting the socket in the posterior direction will help a stronger or more confident walker by facilitating knee flexion at toe off. Shifting the socket in the posterior direction also allows foot function to be optimized and accommodates any finishing difficulties that could be caused by hip contractures.**

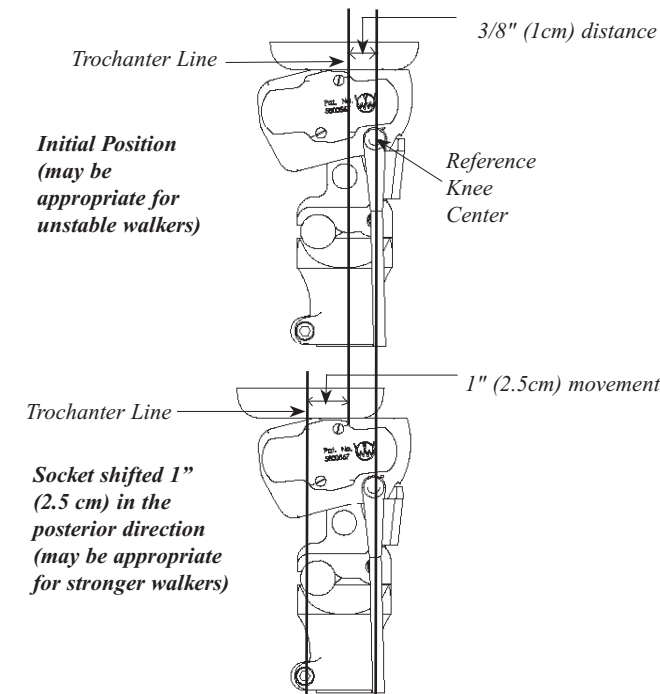

Keep the pylon and knee as vertical as possible in the anterior/posterior and medial/lateral planes to prevent uneven loading of the knee in the medial/lateral plane and difficulty initiating flexion in the anterior/posterior plane.

NOTE: This knee does not have a lock mechanism. Patients who previously used a knee with a lock mechanism may require retraining with this knee.

Friction Control Adjustment

The knee is shipped with the friction control set at its minimum level. To adjust the amount of friction, follow these steps:

- Locate the Friction Control Screw through the slot in the Black Cap that has the GeoFlex or GeoLite logo.
- Using a 5mm Allen wrench, turn the screw **CLOCKWISE** to increase the amount of friction. One complete turn of the screw will result in maximum friction.

NOTE: Continuing to tighten the screw past one complete turn will cause the knee to lock up and will damage the friction control.

- Turn the screw **COUNTERCLOCKWISE** to decrease the amount of friction.

NOTE: Make sure that the Black Cap is installed on the side of the knee. If you attempt to loosen the Friction Control Screw without the Black Cap in place, the screw may back out of the knee and cause internal components to disengage.

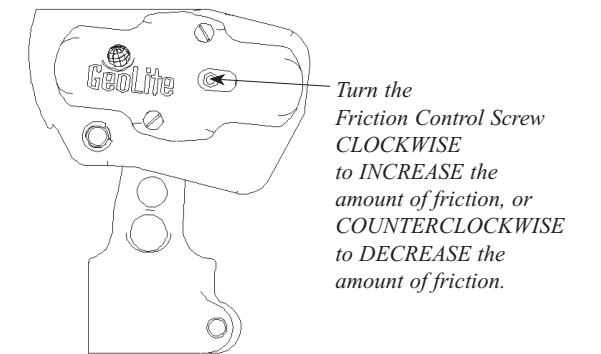

Changing the Stance Flexion Bumper (GeoFlex only)

The stance flexion bumper provides some shock absorption at heel strike. Each GeoFlex is shipped with a firm Stance Flexion Bumper, because it is easiest to initiate knee flexion with a firm bumper. If the bumper is too firm for the amputee to notice any shock absorption, replace the firm (blue) bumper with a medium (red) bumper or a soft (green) bumper.

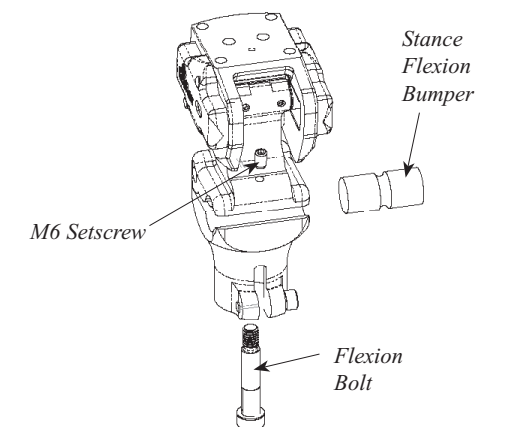

- Remove the M6 Setscrew from the Main Body.
- Remove the Flexion Bolt from the Main Body.
- Slide the old Stance Flexion Bumper out.
- Slide the new Stance Flexion Bumper into the Bumper Cavity.
- Apply a drop of Loctite 242 Removable Threadlocker (or equivalent) onto the threads of the M6 Setscrew.
- Tighten the Setscrew until it is flush with the Main Body.
- Apply Loctite 242 Removable Threadlocker (or equivalent) onto the threads of the Flexion Bolt.
- Insert the Flexion Bolt and tighten to 14 Nm (10 ft-lbs).

Installing the Elastic Extension Assist (Optional)

The Elastic Extension Assist not only provides extension assistance but also helps to prevent damage to the knee and to any cosmetic covering that is applied. Follow these steps for installation:

1. Attach the arms of the Elastic Extension Assist onto the attachment posts on the medial and lateral sides of the knee.
2. Press the Extension Caps through the holes in the Elastic Extension Assist onto the attachment posts.

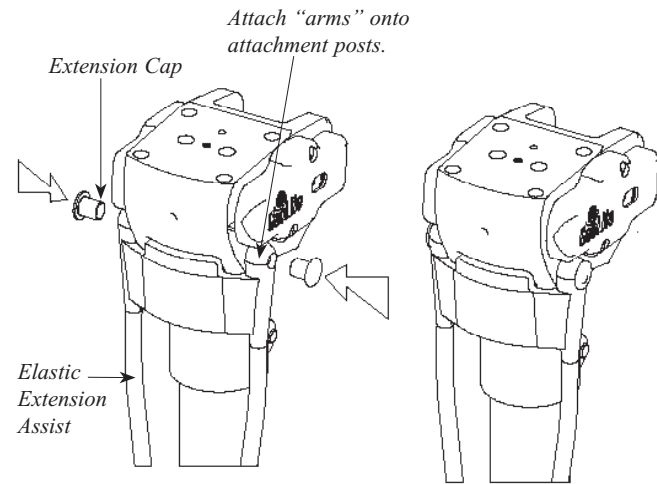

3. Using firm pressure, push each Extension Cap in until it snaps into position.
4. Slide the Elastic Extension Assist Tube Clamp onto the pylon with the hook pointing downward, and hook the Elastic Extension Assist onto the clamp as shown below.

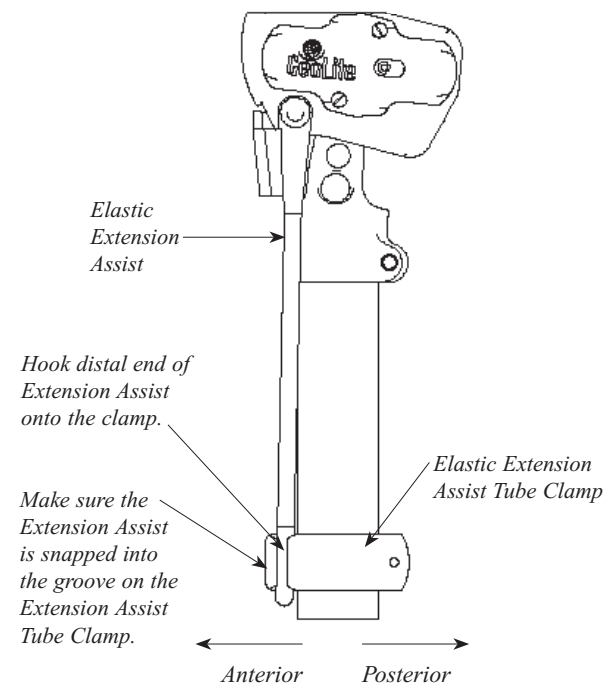

5. Position the Elastic Extension Assist Tube Clamp so that the arms of the Elastic Extension Assist are straight and not twisted, and so that there is equal tension in each of the arms, in order to prevent premature wear of the cover.

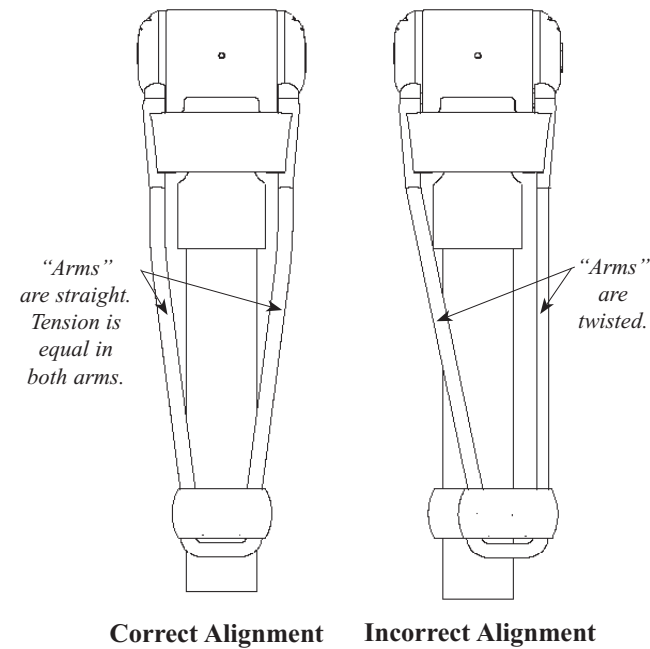

6. Adjust the position of the Elastic Extension Assist Tube Clamp according to the chart on page 8, and hand-tighten the bolt on the clamp.

Options for Using the Elastic Extension Assist

Desired Function of Elastic Extension Assist	Length of Elastic Extension Assist with Knee in Full Extension (refer to drawing below)	Comments
1) As a protective cover only (it does NOT assist in extension).	190mm (7.5")	When the knee is in full flexion, there will be a small amount of tension in the Elastic Extension Assist. This tension helps the Extension Assist to remain in position under a cosmetic covering, but will not be felt by the amputee.
2) As a protective cover AND to assist in extension.	190 - 270mm (7.5" - 10.5")	Stretching the Extension Assist LONGER than 270mm (10.5") provides little additional assist and may result in premature wear of the Extension Assist.

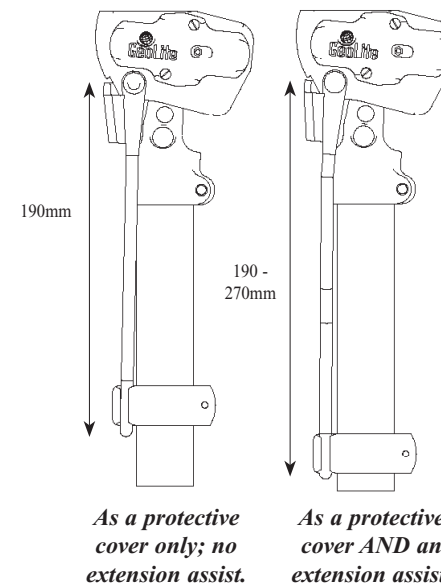

Using the Elastic Extension Assist to Provide Some Flexion Assist

It is possible to install the Elastic Extension Assist so that it provides not just an extension assist, but also a slight amount of flexion assist when the knee is in 90° of flexion. To achieve this, assemble the Elastic Extension Assist as shown in the drawing below.

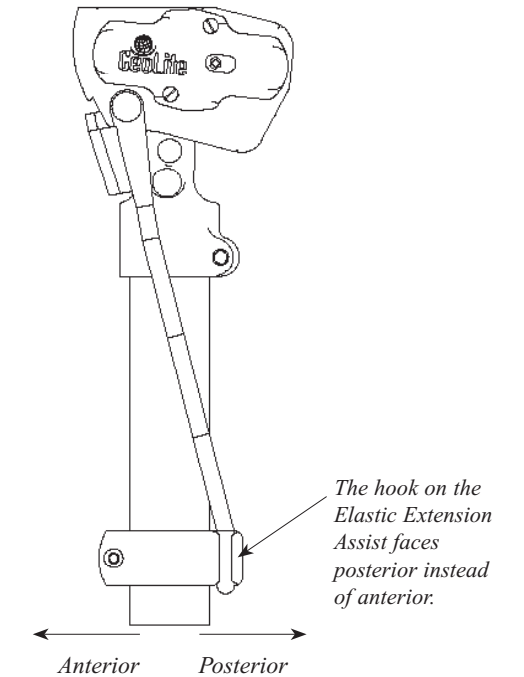

Removing the Extension Assist

Note: The Extension Caps cannot be re-used once they are removed, because they become damaged in the removal process. Please use the replacement Extension Caps included with the knee if you intend to reinstall the Elastic Extension Assist.

1. Break off the circular tabs around the edge of the Extension Caps.
2. Remove the Elastic Extension Assist.
3. Split the Extension Caps with a knife.
4. Remove the Extension Caps with pliers.